

# INDUSTRIAL PULLEY PULLER

3575 Third Ave. P.O. Box 626, Marion, IA 52302, 319-447-2245, Fax: 319-377-1204

## 8-Ton Industrial Pulley Puller Part

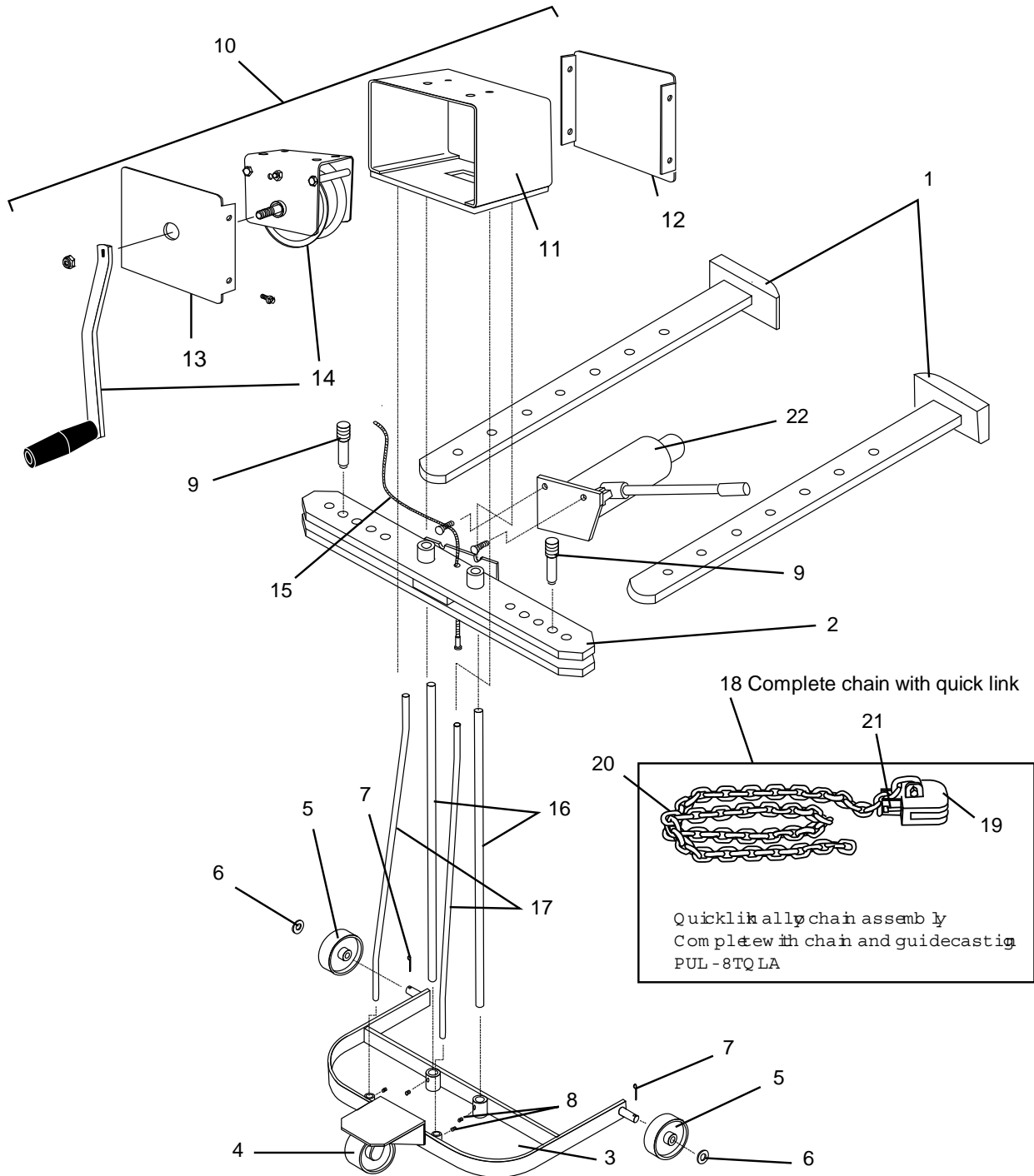

# INDUSTRIAL PULLEY PULLER

3575 Third Ave. P.O. Box 626, Marion, IA 52302, 319-447-2245, Fax: 319-377-1204

## 8-TON INDUSTRIAL PULLEY PULLER PARTS

Ref No.	Part Number	Description
	PUL-8 TON-PP	PORTABLE HYDRAULIC PULLEY PULLER <b>COMPLETE</b> WITH QUICK-LINK CHAIN
1	PUL-8TA	8-TON PULLER ARM ASSEMBLY
2	PUL-8TB	8-TON PULLER BEAM ASSEMBLY
3	PUL-8TC	8-TON CARRIAGE BASE ASSEMBLY
4	PUL-8TC-08	CASTER; SWIVEL #50-A-2
5	PUL-8TC-09	CASTER; STATIONARY #25-2050 PBSE-1-8
6	PUL-8TC-10	AXLE WHEEL WASHER; 8-TON
7	PUL-8TC-11	AXLE WHEEL COTTER PIN; 8-TON
8	PUL-20TH-12	SET SCREW; 5/16" x 3/8"
9	PUL-8 TON PIN	BEAM PIN 20-TON
10	PUL-8TH-NS	8-TON PULLER HEAD ASSEMBLY (COMPLETE)
11	PUL-8/20TH-4	HOUSING
12	PUL-8/20TH-2	COVER
13	PUL-8/20TH-3	COVER (W/HOLE FOR CRANK)
14	PUL-8/20W	WINCH (ONLY)
15	PUL-8/20CABLE	CABLE, 64" LONG
16	PUL-8TU-1	UPRIGHT SUPPORT ROD, 8-TON
17	PUL-8TU-2	UPRIGHT BRACE ROD, 8-TON
18	PUL-8TQLA	QUICKLINK CHAIN ASSEMBLY, 8-TON
19	PUL-8TQ-1	MACHINED QUICKLINK (CASTING ONLY), 8-TON
20	PUL-8TQLC	CHAIN (ONLY), 3/8" x 4'-0" LONG 8-TON
21	73-1600	SQUARE HEAD SETSCREW, 3/8" x 2-1/2"
22	PUL-8TR-3	HYDRAULIC JACK, 8-TON