

INDUSTRIAL PULLEY PULLER

3575 Third Ave. P.O. Box 626, Marion, IA 52302, 319-447-2245, Fax: 319-377-1204

60-Ton Industrial Pulley Puller Parts

These head parts are no-longer available. Use head assembly part number PUL-60TH-A

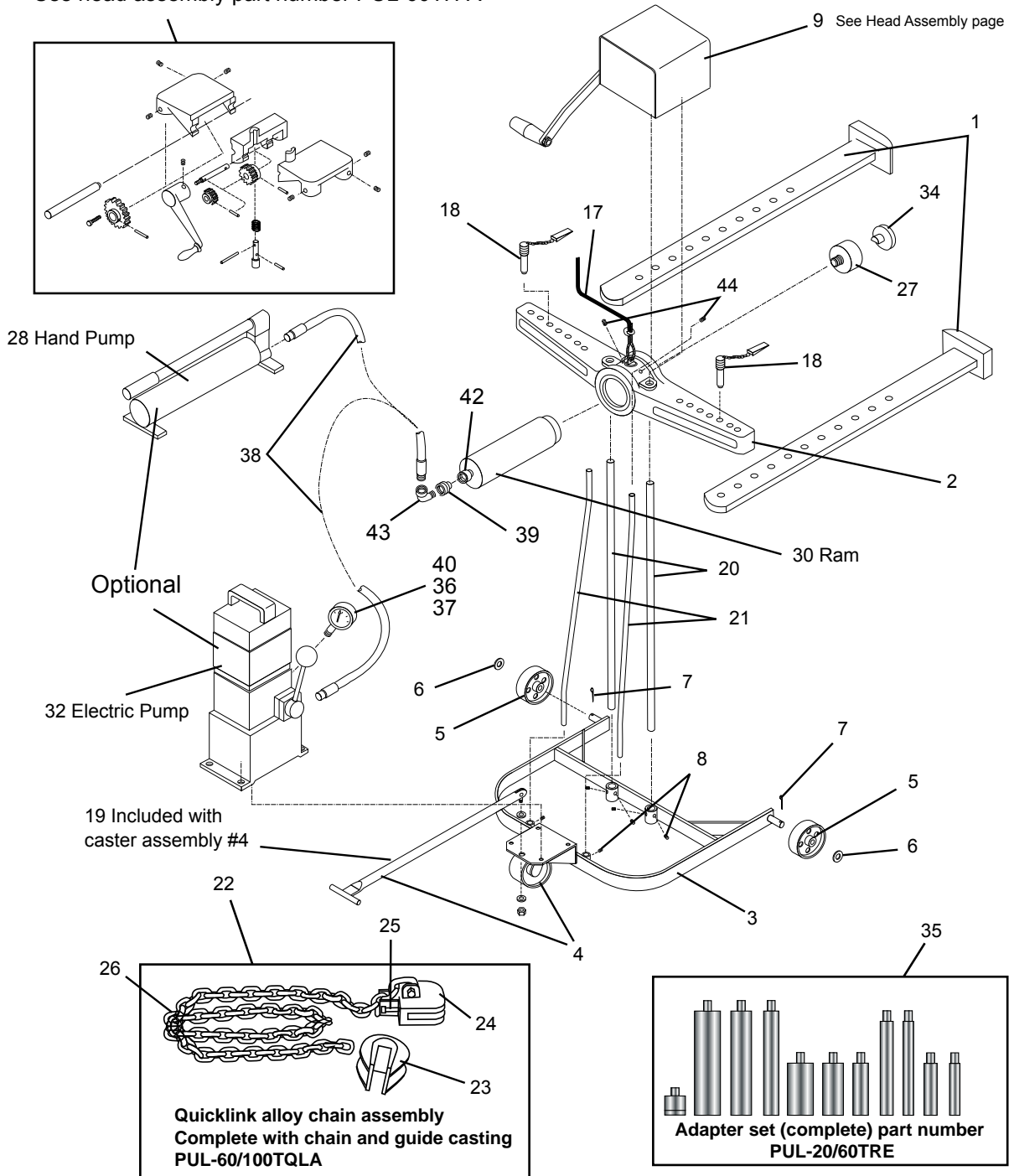

P.O. Box 626 • 3575 3rd Ave. • Marion, IA 52302 • Ph: 319.447.2245 • Fax: 319.377.1204
 e-mail:sales@pulleypuller.com • Home Page: www.pulleypuller.com

INDUSTRIAL PULLEY PULLER

3575 Third Ave. P.O. Box 626, Marion, IA 52302, 319-447-2245, Fax: 319-377-1204

Head Assembly for 60-Ton Pulley Puller complete with winch PUL-60TH-A

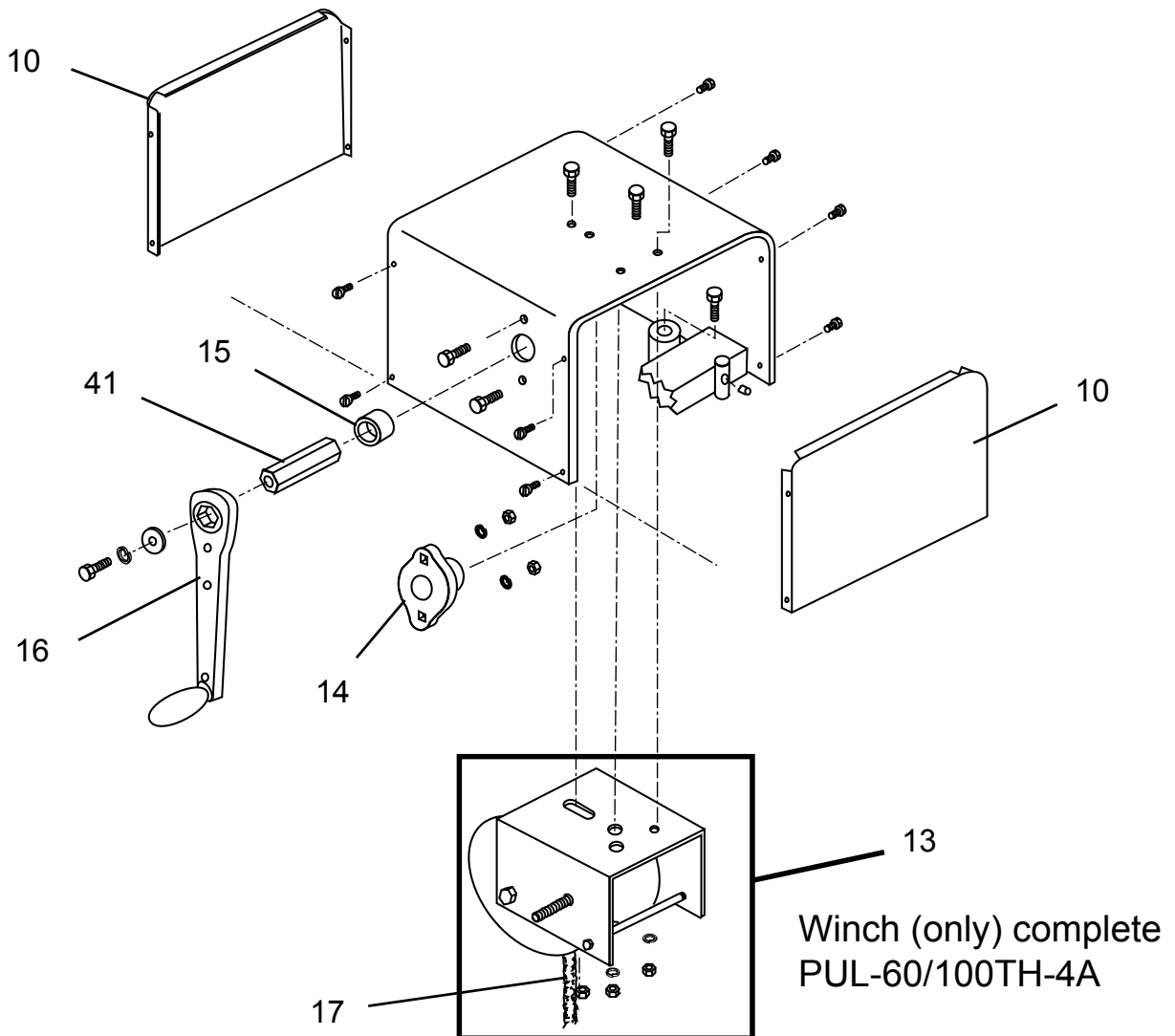

INDUSTRIAL PULLEY PULLER

3575 Third Ave. P.O. Box 626, Marion, IA 52302, 319-447-2245, Fax: 319-377-1204

60-TON PULLEY PULLER REPLACEMENT PARTS LIST

REF NO.	PART NUMBER	DESCRIPTION
	PUL-60 TON-ELPP	60-TON PORTABLE HYDRAULIC PULLEY PULLER WITH <u>ELECTRICALLY</u> OPERATED (115/1/60) HYDRAULIC PUMP, COMPLETE WITH QUICK-LINK CHAIN ATTACHMENT AND SET OF RAM ADAPTERS
	PUL-60 TON-PP	60-TON PORTABLE HYDRAULIC PULLEY PULLER WITH <u>MANUALLY</u> OPERATED HYDRAULIC PUMP, COMPLETE WITH QUICK-LINK CHAIN ATTACHMENT AND SET OF RAM ADAPTERS
1	PUL-60TA	60-TON PULLER ARM ASSEMBLY
2	PUL-60TB	60-TON PULLER BEAM ASSEMBLY
3	PUL-60TC	CARRIAGE BASE ASSEMBLY; 60-TON
4	PUL-60/100TC-8	CASTER; SWIVEL #1442-A-6
5	PUL-60/100TC-9	CASTER; STATIONARY #1-8-BC-2-12
6	PUL-60/100TC-10	AXLE WHEEL WASHER; 60/100-TON
7	PUL-60/100TC-11	AXLE COTTER PIN; 60/100-TON
8	PUL-60/100TC-12	5/16"-24 x 3/8" SET SCREW
9	PUL-60TH-A	HEAD ASSEMBLY; 60-TON (COMPLETE WITH WINCH)
10	PUL-60/100TH-1A	END COVER
13	PUL-60/100TH-4A	WINCH, K-1550-0301
14	PUL-60/100TH-6A	BEARING, VF2S-116M, 1" DIA. X
15	PUL-60/100TH-7A	SET COLLAR, 1" ID X 1.5" OD #6432
16	PUL-60/100TH-9A	CRANK, #21-83714-4SLR
17	PUL-60/100TH-10A	CABLE ASSM. 1/4" X 60/100 TON
18	PUL-60TP-1	BEAM PIN ASSEMBLY; 60-TON
19		INCLUDED WITH CASTER ASSEMBLY #4
20	PUL-60/100TU-1	UPRIGHT SUPPORT ROD; 60/100 TON
21	PUL-60TU-2	UPRIGHT BRACE ROD; 100-TON
22	PUL-60/100TQLA	QUICK-LINK CHAIN ASSY; 60/100 TON
23	PUL-60/100TQ-1	GUIDE CASTING; 60/100 TON
24	PUL-60/100TQ-2A	CHAIN CASTING, MACHINE; 60/100 TON
25	PUL-60/100TQ-BT	5/8"-11 X 5" SQ.SET SCREW
26	PUL-60/100TQLC	CHAIN (ONLY) 1/2" x 60/100 TON
27	PUL-60TRC-ASMB	60 TON RAM ADAPTER
28	PUL-60TR-1	MANUAL PUMP 2-STAGE (HP-150)
29	PUL-60TR-KIT-1	REPAIR KIT; #X7876 (HP-150)
30	PUL-60TR-3	RAM; 60 TON (CSR6011-IES)
31	PUL-60TR-KIT-2	REPAIR KIT; #X80812 (CSR6011-IES)
32	PUL-20TR-IEL	ELEC. PUMP 3-WAY (HUP-180-3RC)
33	PUL-20TR-KIT-2	REPAIR KIT; #X308-SK (HUP-180-3RC)
34	PUL-20/60TRP	RAM PLUG; 20/60-TON
35	PUL-20/60TRE	RAM ADAPTER SET; 20/60-TON
36	PUL-HA-119	HA-119; STREET ELBOW
37	PUL-HA-120	HA-120; PIPE REDUCER
38	PUL-TR-2	HYD. HOSE X 6'-0" (HA-86-72)
39	PUL-20TR-5	COUPLER-HOSE HALF; (HA-17)
40	PUL-100TR-6	10,000 PSI PRESSURE GAUGE (HA-90)
41	PUL-60/100TH-5A	HEX CRANK, 7/8" HEX X 45/16"
42	PUL-20TR-4	RAM COUPLER (HA-18)
43	PUL-100TR	3/8" STREET ELBOW
44		SETScrew, 3/8"