

INDUSTRIAL PULLEY PULLER

3575 Third Ave. P.O. Box 626, Marion, IA 52302, 319-447-2245, Fax: 319-377-1204

100-ton "Low-Profile" Industrial Pulley Puller Parts

Complete part number P UL-100 TON-LPE (Electric)

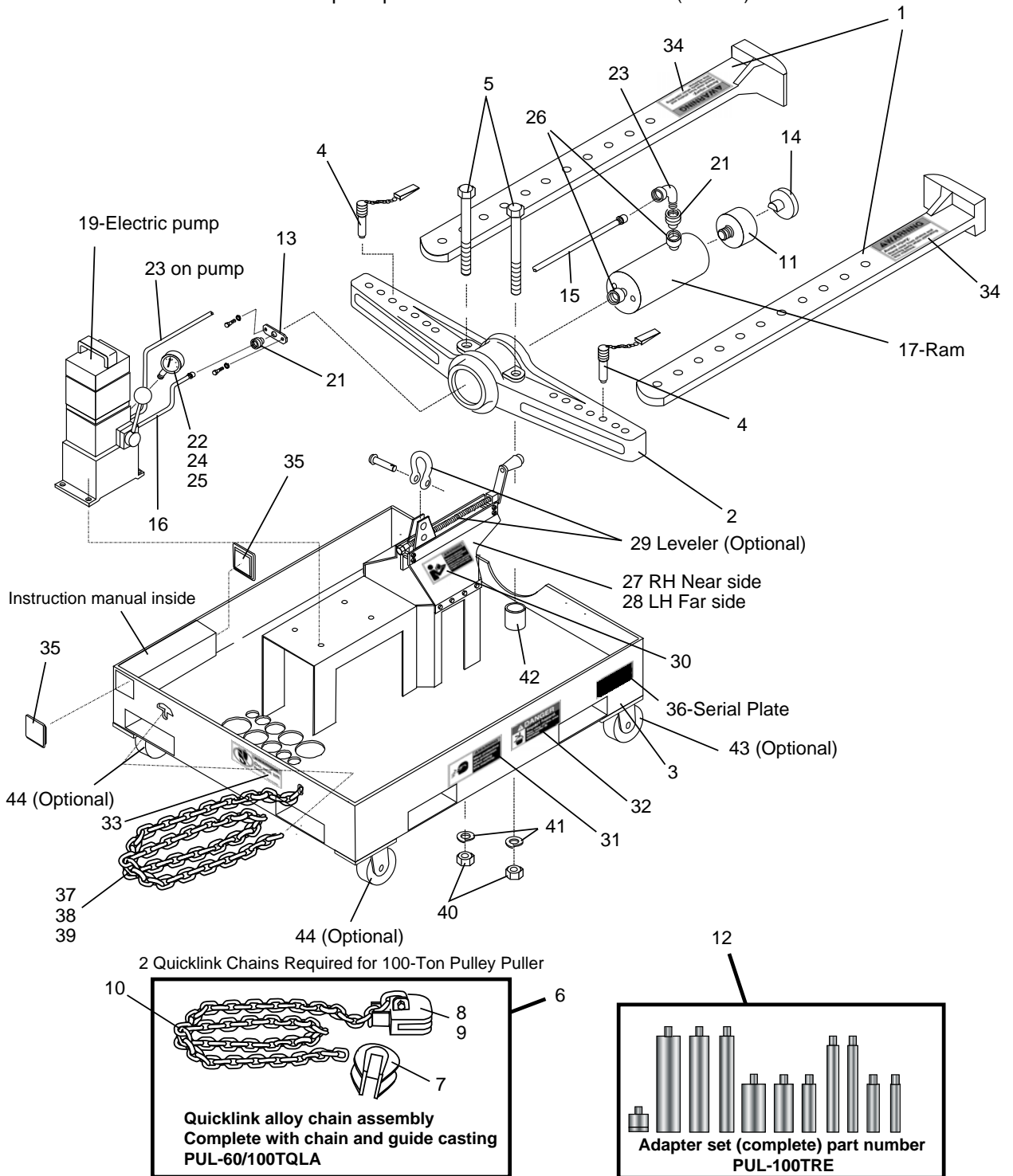

INDUSTRIAL PULLEY PULLER

3575 Third Ave. P.O. Box 626, Marion, IA 52302, 319-447-2245, Fax: 319-377-1204

100-ton "Low-Profile" Industrial Pulley Puller Parts

Ref. No.	Part Number	Description	Quantity
	PUL-100 TON-LPE (COMPLETE)	100-TON LOW-PROFILE PULLER COMPLETE WITH ELECTRIC PUMP, 2 QUICKLINK CHAIN ASSEMBLIES AND SET OF RAM ADAPTERS	
1	PUL-100TA	100-TON PULLER ARM ASSEMBLY (single arm)	2
2	PUL-100TB	100-TON PULLER BEAM	1
3	PUL-LP-BASE	PLATFORM BASE	1
4	PUL-100TP-1	BEAM PIN ASSEMBLY; 100-TON	2
5	PUL-LP-B20	HHCS 1-1/4-7 x 11" Grade 5 PLTD	2
6	PUL-60/100TQLA	QUICKLINK CHAIN ASSEMBLY (WITH CHAIN AND GUIDE CASTING) (2 CHAINS REQUIRED FOR 100-TON PULLEY PULLER)	2
7	PUL-60/100TQ-1	GUIDE CASTING (ONLY); 60/100 TON	2
8	PUL-60/100TQ-2A	CHAIN CASTING (ONLY); 60/100 TON	2
9	PUL-60/100TQ-BT	5/8"-11 X 5" SET SCREW	4
10	PUL-60/100TQLC	CHAIN (ONLY)	2
11	PUL-60/100TRC	100 TON RAM ADAPTER ASSEMBLY	1
12	PUL-100TRE	100 TON RAM ADAPTER SET (Includes 10 adapters)	1
13	PUL-100TRB	JACK RETAINING BAR; 100 TON	1
14	PUL-100TRP	RAM PLUG; 100 TON	1
15	PUL-HH-33	HYDRAULIC HOSE	1
16	PUL-HH-27	HYDRAULIC HOSE	1
17	PUL-100TR-3	RAM; 100 TON (RC-100-DA-6-IES)	1
18	*** PUL-100TR-KIT-1	REPAIR KIT; #X7071-A (RC-100-DA-6-IES) (For Ram)	
19	PUL-100TR-IEL	ELECTRIC PUMP 4-WAY (HUP-180-4R)	1
20	*** PUL-100TR-KIT-2	REPAIR KIT; #X8308-SK (HUP-180-4R) (For Pump)	
21	PUL-20TR-5	COUPLER-HOSE HALF; HA-17	2
22	PUL-100TR-6	10,000 PSI PRESSURE GAUGE (HA-90) ELECTRIC (ONLY)	1
23	PUL-100TR-ELBOW	3/8"-3000#; STREET ELBOW	1
24	*** PUL-HA-119	STREET ELBOW (NOT SHOWN) (On Gauge)	1
25	*** PUL-HA-120	PIPE REDUCER (NOT SHOWN) (On Gauge)	1
26	PUL-100TR-4	RAM COUPLER (HA-18)	2
27	Call	BRACKET LEVELER -RIGHT SIDE (NEAR SIDE)	1
28	Call	BRACKET LEVELER-LEFT SIDE (FAR SIDE)	1
29		SEE LEVELER PARTS (optional)	
30	35-0030	DECAL, READ MANUAL	2
31	35-0032	DECAL, WEAR EYE PROTECTION	2
32	35-0036	DECAL, IMPACT HAZARD	2
33	35-0040	DECAL, DO NOT LIFT HERE	2
34	35-0034	DECAL, STAND CLEAR	4
35	PUL-LP-B18	PLUG, RUBBER	2
36	PUL-TAG	SERIAL PLATE	1
37	PUL-8TQLC	CHAIN, SUPPORT	2
38	67-1200	HHCS, 1/2"-13 X 1-1/4"	2
39	69-0460	LOCKNUT, 1/2"-13	2
40	69-0850	HEX NUT, 1-1/4-7 Grade 5 PLTD	2
41	70-0800	LOCKWASHER 1-1/4 PLTD	2
42		SPACER, 2" ID x 5/16" WALL x 2-3/4"LONG	2
43	45-3887	CASTER, RIGID - RAM END (OPTIONAL)	2
44	45-3889	CASTER, SWIVEL - PUMP END (OPTIONAL)	2

*** NOT SHOWN ON DRAWING

INDUSTRIAL PULLEY PULLER

3575 Third Ave. P.O. Box 626, Marion, IA 52302, 319-447-2245, Fax: 319-377-1204

Leveler Parts - Low-Profile Puller

Part Number PUL-Leveler

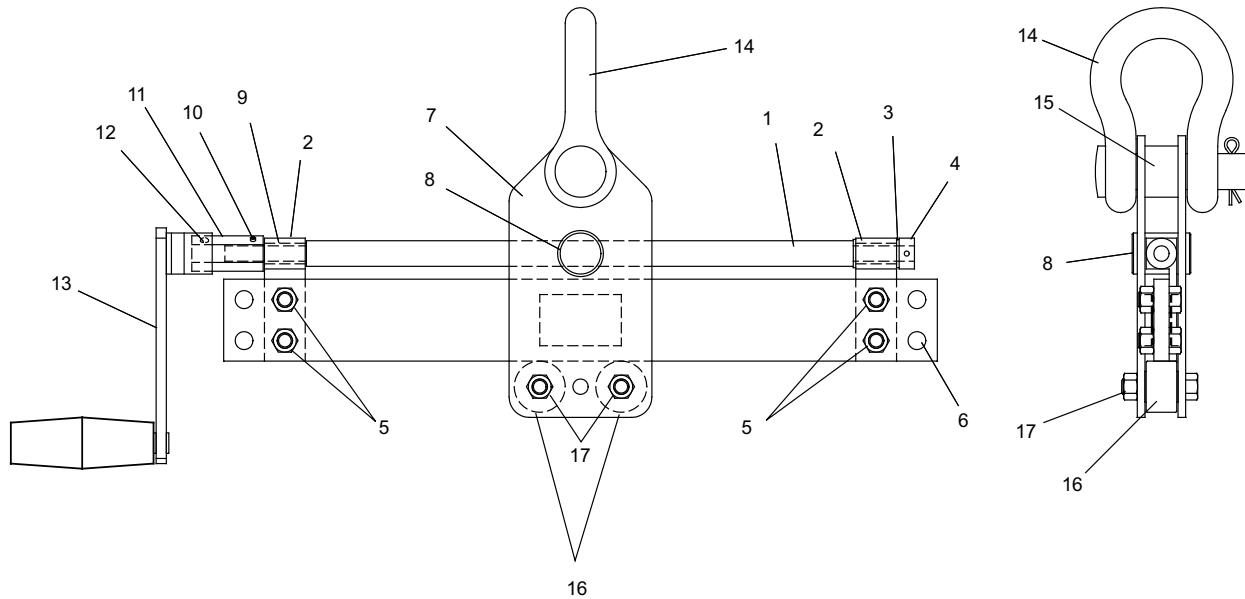

Ref. No.	Part Number	Description	Quantity
	PUL-Leveler	Leveler - complete	
1	PUL-LV--02	Feed screw	1
2	PUL-LV-06	Support block	2
3	45-0860	Flanged bushing, 3/8" ID x 1/2" OD x 1/2" LG	2
4	45-4660	Set collar	1
5		Hexbolt, 3/8" - 16 x 1"	4
		Lockwasher, 3/8"	4
		Hex nut	4
6	PUL-LV-16	Spacer	8
7	PUL-LV-12	Side plate	2
8	PUL-LV-10	T- bar nut	1
9	45-0865	Bushing, 3/8" ID x 1/2" OD x 1" LG	1
10	PUL-20TH-07	Pin, 1/8" Dia. x 7/8" LG	1
11	PUL-LV-04	Hex adapter	1
12	PUL-DB-10	Detent ball, 3/8 - 16 UNC	1
13	PUL-LV-HNDL	Handle assembly	1
14	PUL-LV-08	Shackle, 4-3/4 ton	1
15		Spacer	1
16	PUL-LV-18	Track Roller	1
17		Socket head cap screw	2
		Ny-lock hex nut	2