

# INDUSTRIAL PULLEY PULLER

3575 Third Ave. P.O. Box 626, Marion, IA 52302, 319-447-2245, Fax: 319-377-1204

## 100-Ton Industrial Pulley Puller Parts complete part number PUL-100 TON PP

These head parts are no-longer available.  
Use new head assembly PUL-100TH-A

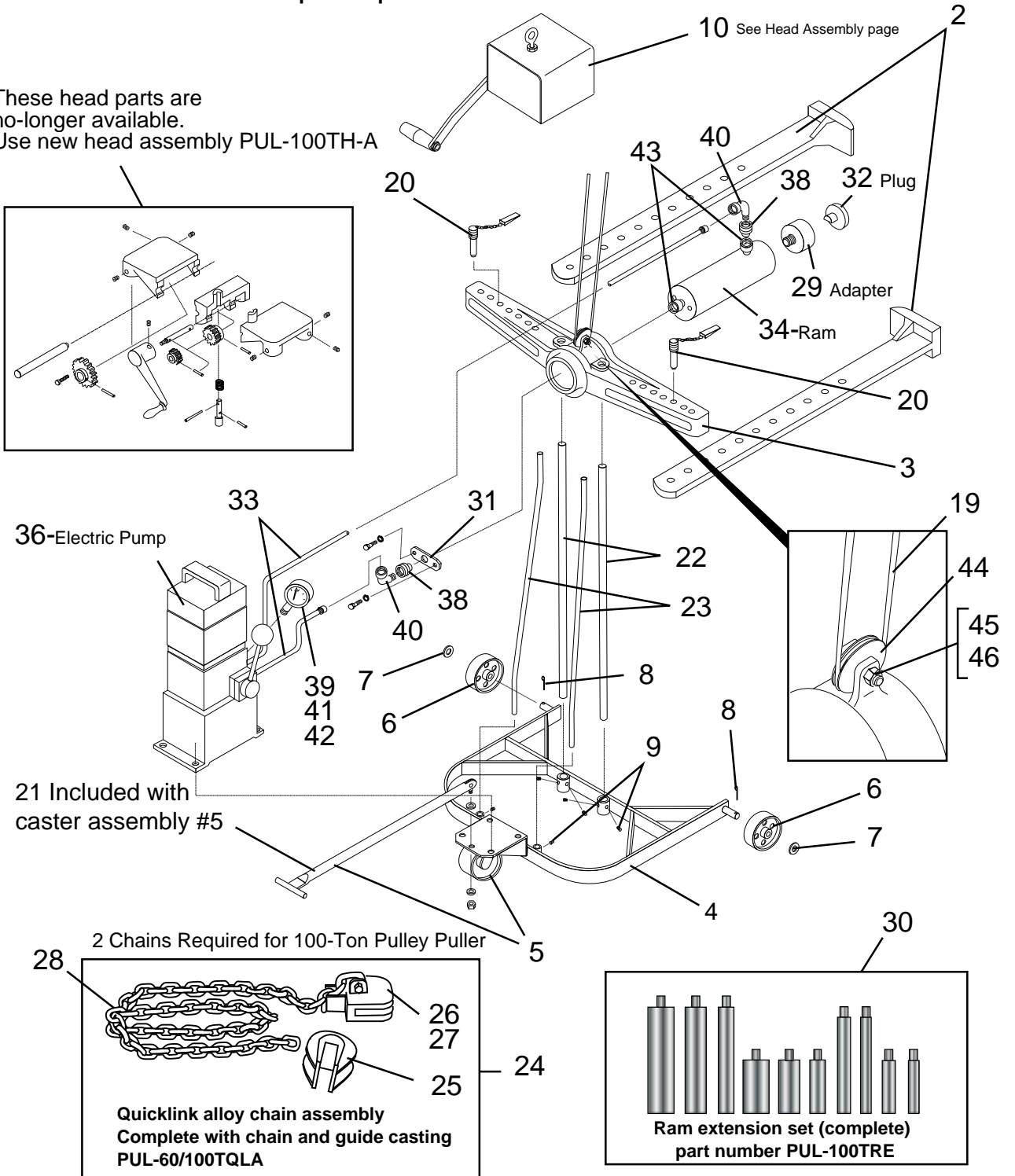

# INDUSTRIAL PULLEY PULLER

3575 Third Ave. P.O. Box 626, Marion, IA 52302, 319-447-2245, Fax: 319-377-1204

## Head Assembly for 100-Ton Pulley Puller complete with winch PUL-100TH-A

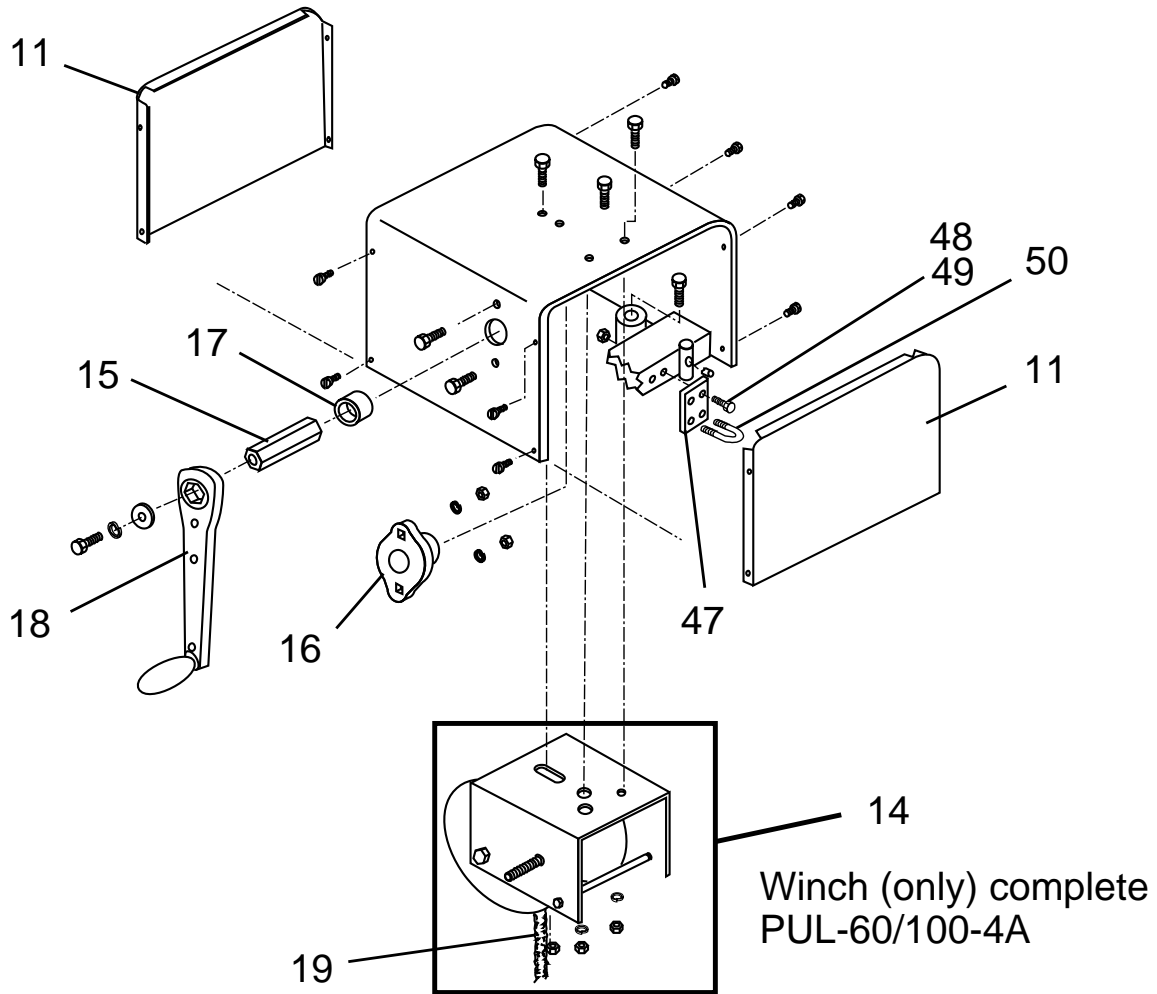

# INDUSTRIAL PULLEY PULLER

3575 Third Ave. P.O. Box 626, Marion, IA 52302, 319-447-2245, Fax: 319-377-1204

## 100-Ton Industrial Pulley Puller Parts

complete part number PUL-100 TON PP

1	PUL-100 TON PP (Complete)	}	100-TON PORTABLE HYDRAULIC PULLEY PULLER WITH ELECTRICALLY OPERATED (115/1/60) HYDRAULIC PUMP, COMPLETE WITH 2 QUICK-LINK CHAIN ATTACHMENTS AND SET OF RAM ADAPTERS
2	PUL-100TA		100-TON PULLER ARM ASSEMBLY (single arm)
3	PUL-100TB	100-TON PULLER BEAM	
4	PUL-100TC	100-TON CARRIAGE BASE	
5	PUL-60/100TC-8	CASTER; SWIVEL #1442-A-6	
6	PUL-60/100TC-9	CASTER; STATIONARY #1-8-BC-2-12	
7	PUL-60/100TC-10	AXLE WHEEL WASHER; 60/100-TON	
8	PUL-60/100TC-11	AXLE COTTER PIN; 60/100-TON	
9	PUL-60/100TC-12	5/16"-24 x 3/8" SET SCREW	
10	PUL-100TH-A	HEAD ASSEMBLY; 100-TON (Complete with winch)	
11	PUL-60/100TH-1A	END COVER	
12	PUL-60/100TH-3A	EYE BOLT LIFTING 3/4"X2" #42317	
13	PUL-60/100TH-3B	LOCKNUT, NYLON INSERT 3/4"-10	
14	PUL-60/100TH-4A	WINCH, K-1550-0301 (Complete)	
15	PUL-60/100TH-5A	HEX CRANK 7/8" HEX X 4-5/16"	
16	PUL-60/100TH-6A	BEARING, VF2S-116M, 1" DIA. X	
17	PUL-60/100TH-7A	SET COLLAR, 1" IDX1.5"OD #6432	
18	PUL-60/100TH-9A	CRANK, #21-83714-4SLR	
19	PUL-CABLE-86"	CABLE ASSM. 86" LONG	
20	PUL-100TP-1	BEAM PIN ASSEMBLY; 100-TON	
21		INCLUDED WITH #5 CASTER ASSEMBLY	
22	PUL-60/100TU-1	UPRIGHT SUPPORT ROD; 60/100 TON	
23	PUL-100TU-2	UPRIGHT BRACE ROD; 100-TON	
24	PUL-60/100QLA	QUICK-LINK CHAIN ASSEMBLY (with chain and guide casting)	
25	PUL-60/100TQ-1	GUIDE CASTING; 60/100 TON (only)	
26	PUL-60/100TQ-2A	CHAIN CASTING, MACHINE; 60/100 TON (only)	
27	PUL-60/100TQ-BT	5/8"-11 X 5" SQ.SET SCREW	
28	PUL-60/100TQLC	CHAIN ONLY 1/2" x 60/100 TON	
29	PUL-100TRC-ASMB	100 TON RAM ADAPTER ASSEMBLY	
30	PUL-100TRE	100-TON RAM ADAPTER SET	
31	PUL-100TRB	JACK RETAINING BAR; 100-TON	
32	PUL-100TRP	RAM PLUG; 100-TON	
33	PUL-TR-2	HYD. HOSE X 6'-0" ( HA-86-72)	
34	PUL-100TR-3	RAM;100 TON (RC-100-DA-6-IES)	
35	PUL-100TR-KIT-1	REPAIR KIT; #X7071-A (RC-100-DA-6-IES)	
36	PUL-100TR-1EL	ELECTRIC PUMP 4-WAY (HUP-180-4R)	
37	PUL-100TR-KIT-2	REPAIR KIT; #X8308-SK (HUP-180-4R)	
38	PUL-20TR-5	COUPLER-HOSE HALF; (HA-17)	
39	PUL-100TR-6	10,000 PSI PRESSURE GAUGE (HA-90)	
40	PUL-100TR-ELBOW	3/8"-3000#; STREET ELBOW	
41	PUL-HA-119	STREET ELBOW (not shown)	
42	PUL-HA-120	PIPE REDUCER (not shown)	
43	PUL-100TR-4	RAM COUPLER (HA-18)	
44	PUL-SHEAVE-03	SHEAVE 1/4" X 3" DIA.	
45	73-4220-125	SHOULDER BOLT 1/2"	
46	69-0280	LOCKNUT	
47	PUL-CLAMPBRKT	CABLE CLAMP BRACKET	
48	67-0300	SCREW 5/16"-18 X 3/4"	
49	70-0200	LOCKWASHER 5/16"	
50	PUL-CLAMP-02	CABLE CLAMP 1/4"	